

# HULK<sup>®</sup> SERIES KRL RAIL LIFT

L I F T P R O D U C T S P E C I F I C A T I O N S

## Design Highlights

- Low Profile for Surface-mounted Applications
- No Pit Construction Required
- Three-sided Platform
- Heavy-duty I-beam Deck Understructure
- Excellent End-load Stability in Fully Raised Position
- Displacement-style Cylinders with Internal Stops
- Self-contained Power Unit/control Panel
- Standard Pre-wired Control Panel
- NEMA 4X Push-button with 15' Cord
- Superior Speed-to-horsepower Ratio Compared to Scissor-style Dock Lifts
- Direct-thrust Cylinders Provide Constant Speed Through Full Range of Travel
- Checker Plate or Smooth Deck Surface
- Sealed Guide Bearing Rollers

## Project Information

Job Name \_\_\_\_\_  
 Address \_\_\_\_\_  
 General Contractor \_\_\_\_\_  
 Distributor \_\_\_\_\_  
 Quantity \_\_\_\_\_  
 Voltage \_\_\_\_\_ Phase \_\_\_\_\_

## Certified For Construction

By \_\_\_\_\_  
 Company \_\_\_\_\_  
 Address \_\_\_\_\_  
 Date \_\_\_\_\_

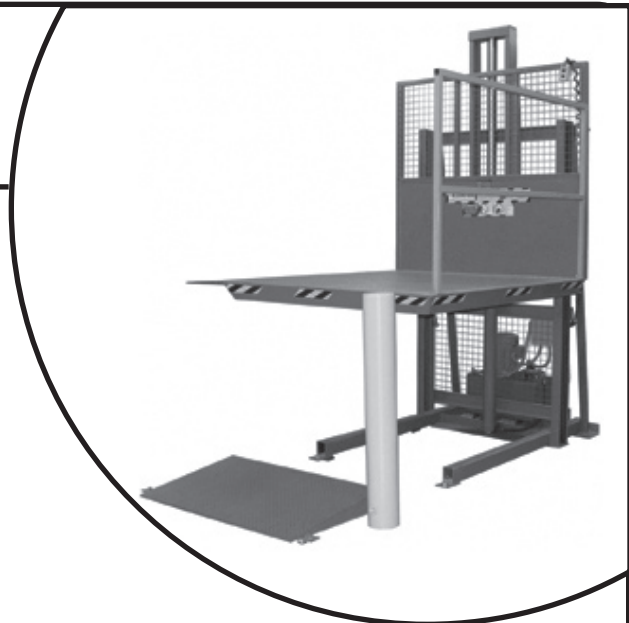

## Available Options

- Aluminum Bridges
- Swing Arms
- In Motor Warning Beeper and Flashing Light on a post X 60" High or Wall Mounted on Bracket
- Increased Horsepower Available
- Larger Steel Bridges
- Other \_\_\_\_\_



# HULK<sup>®</sup> SERIES KRL RAIL LIFT

L I F T P R O D U C T S P E C I F I C A T I O N S



Model No.	Lift Capacity [lbs.]	Deck Size [in]	Feet Per Minute [FPM]	HP	Ship. Weight [lb]
KRL45-4	4,000	48 x 60	9	2	2,050
KRL46-4	4,000	48 x 72	9	2	2,200
KRL55-4	4,000	60 x 60	9	2	2,150
KRL56-4	4,000	60 x 72	9	2	2,500
KRL57-4	4,000	60 x 84	9	2	2,650
KRL58-4	4,000	60 x 96	9	2	2,800
KRL66-4	4,000	72 x 72	9	2	2,800
KRL67-4	4,000	72 x 84	9	2	2,950
KRL68-4	4,000	72 x 96	9	2	3,100
KRL610-4	4,000	72 x 120	9	2	3,300
KRL612-4	4,000	72 x 144	9	2	3,600
KRL45-6	6,000	48 x 60	7	2	2,200
KRL46-6	6,000	48 x 72	7	2	2,400
KRL55-6	6,000	60 x 60	7	2	2,400
KRL56-6	6,000	60 x 72	7	2	2,750
KRL57-6	6,000	60 x 84	7	2	2,875
KRL58-6	6,000	60 x 96	7	2	3,000
KRL66-6	6,000	72 x 72	7	2	3,100
KRL67-6	6,000	72 x 84	7	2	3,250
KRL68-6	6,000	72 x 96	7	2	3,400
KRL610-6	6,000	72 x 120	7	2	3,700
KRL612-6	6,000	72 x 144	7	2	3,900