

**HULK® SERIES KHD L DOCK LIFT - HEAVY CAPACITY**

**L I F T P R O D U C T S S P E C I F I C A T I O N S**

**Design Highlights**

- High-tensile Strength, Structural Tubing Construction for Maximum Stability
- Beveled Toe Guards
- 18" Full or Split Bridge Plate
- Dual Lifting Cylinders for Optimum Performance
- Velocity Fuses on Lift Cylinders Prevent Lift from Free Falling in the Event of Hydraulic Failure
- Pre-wired Nema 4x Push Button Control With 15' Cord
- Removable, Mandrel Formed Tubing Handrails
- Maintenance Safety Strut
- Removable Lifting Lugs
- Meets Ansi MH29.1 Safety Requirements for Industrial Scissor Lifts
- Upper Travel Limit Switch
- Oil Sight Gauge in Hydraulic Reservoir
- Self-lubricating Bushings
- Standard 25' Hydraulic Hose
- Low Temperature Oil
- Two-year Parts, One-year Labor Warranty
- UL Approved Panel

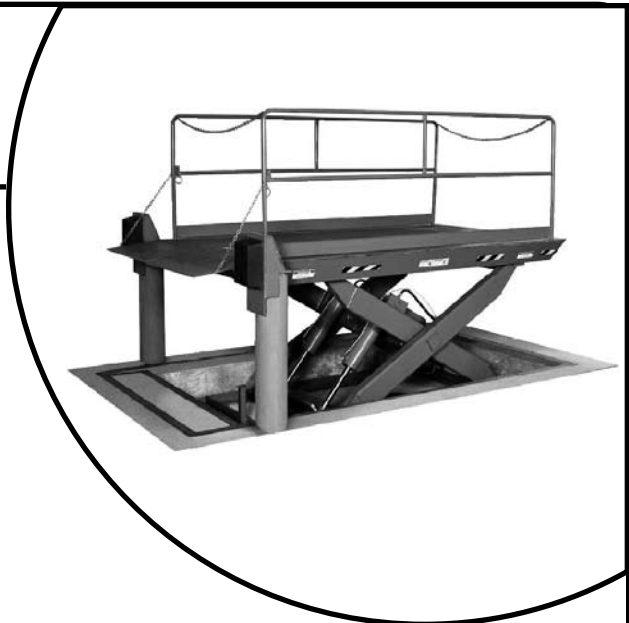

**Available Options**

- Electric Toe Guards
- Aluminum Bridge Plates
- Post Office Option Package
- Hot Dipped Galvanized
- Spring-assisted Bridge
- In-motion Warning Beeper and Flashing Light
- Roller Curtains
- Accordion Bellow Skirting
- Hydraulic Pop-up Stop
- Mechanical Pop-up Stop
- Hydraulic Lip
- Biodegradable Oil
- Special Sizes
- Other \_\_\_\_\_

**Project Information**

Job Name \_\_\_\_\_

Address \_\_\_\_\_

General Contractor \_\_\_\_\_

Distributor \_\_\_\_\_

Model \_\_\_\_\_ Quantity \_\_\_\_\_ Voltage/Phase \_\_\_\_\_



# HULK® SERIES KHDL DOCK LIFT - HEAVY CAPACITY

## L I F T P R O D U C T S S P E C I F I C A T I O N S

| Model No.  | Travel [in] | Capacity [lb] | Standard Platform [in] | Max. End Load [lb] | Max. Side Load [lb] | Lowered Height [in] | HP  | Raise Lower Speed [fpm] | Ship Weight [lb] |
|------------|-------------|---------------|------------------------|--------------------|---------------------|---------------------|-----|-------------------------|------------------|
| KHDL68-10  | 60          | 10,000        | 72 x 96                | 7,500              | 5,000               | 14                  | 7.5 | 9                       | 3,200            |
| KHDL68-12  | 60          | 12,000        | 72 x 96                | 9,000              | 6,000               | 14                  | 7.5 | 9                       | 3,350            |
| KHDL68-15  | 60          | 15,000        | 72 x 96                | 11,200             | 7,500               | 14                  | 7.5 | 9                       | 3,450            |
| KHDL68-20  | 60          | 20,000        | 72 x 96                | 15,000             | 10,000              | 18                  | 10  | 12                      | 5,500            |
| KHDL69-10  | 60          | 10,000        | 72 x 108               | 7,500              | 5,000               | 14                  | 7.5 | 9                       | 3,240            |
| KHDL69-12  | 60          | 12,000        | 72 x 108               | 9,000              | 6,000               | 14                  | 7.5 | 9                       | 3,390            |
| KHDL69-15  | 60          | 15,000        | 72 x 108               | 11,200             | 7,500               | 14                  | 7.5 | 9                       | 3,490            |
| KHDL69-20  | 60          | 20,000        | 72 x 108               | 15,000             | 10,000              | 18                  | 10  | 12                      | 5,640            |
| KHDL610-10 | 60          | 10,000        | 72 x 120               | 7,500              | 5,000               | 14                  | 7.5 | 9                       | 3,360            |
| KHDL610-12 | 60          | 12,000        | 72 x 120               | 9,000              | 6,000               | 14                  | 7.5 | 7.5                     | 3,510            |
| KHDL610-15 | 60          | 15,000        | 72 x 120               | 11,200             | 7,500               | 14                  | 7.5 | 7.5                     | 3,610            |
| KHDL610-20 | 60          | 20,000        | 72 x 120               | 15,000             | 10,000              | 18                  | 10  | 10                      | 6,000            |
| KHDL612-10 | 60          | 10,000        | 72 x 144               | 7,500              | 5,000               | 14                  | 7.5 | 7                       | 4,140            |
| KHDL612-12 | 60          | 12,000        | 72 x 144               | 9,000              | 6,000               | 14                  | 7.5 | 7                       | 4,290            |
| KHDL612-15 | 60          | 15,000        | 72 x 144               | 11,200             | 7,500               | 14                  | 7.5 | 7                       | 4,390            |
| KHDL612-20 | 60          | 20,000        | 72 x 144               | 15,000             | 10,000              | 18                  | 10  | 9                       | 6,520            |
| KHDL78-10  | 60          | 10,000        | 84 x 96                | 7,500              | 5,000               | 14                  | 7.5 | 9                       | 3,280            |
| KHDL78-12  | 60          | 12,000        | 84 x 96                | 9,000              | 6,000               | 14                  | 7.5 | 9                       | 3,430            |
| KHDL78-15  | 60          | 15,000        | 84 x 96                | 11,200             | 7,500               | 14                  | 7.5 | 9                       | 3,530            |
| KHDL78-20  | 60          | 20,000        | 84 x 96                | 15,000             | 10,000              | 18                  | 10  | 12                      | 5,670            |
| KHDL79-10  | 60          | 10,000        | 84 x 108               | 7,500              | 5,000               | 14                  | 7.5 | 9                       | 3,420            |
| KHDL79-12  | 60          | 12,000        | 84 x 108               | 9,000              | 6,000               | 14                  | 7.5 | 9                       | 3,570            |
| KHDL79-15  | 60          | 15,000        | 84 x 108               | 11,200             | 7,500               | 14                  | 7.5 | 9                       | 3,670            |
| KHDL79-20  | 60          | 20,000        | 84 x 108               | 15,000             | 10,000              | 18                  | 10  | 12                      | 5,800            |
| KHDL710-10 | 60          | 10,000        | 84 x 120               | 7,500              | 5,000               | 14                  | 7.5 | 9                       | 3,600            |
| KHDL710-12 | 60          | 12,000        | 84 x 120               | 9,000              | 6,000               | 14                  | 7.5 | 7.5                     | 3,750            |
| KHDL710-15 | 60          | 15,000        | 84 x 120               | 11,200             | 7,500               | 14                  | 7.5 | 7.5                     | 3,850            |
| KHDL710-20 | 60          | 20,000        | 84 x 120               | 15,000             | 10,000              | 18                  | 10  | 10                      | 6,210            |
| KHDL712-10 | 60          | 10,000        | 84 x 144               | 7,500              | 5,000               | 14                  | 7.5 | 7                       | 4,420            |
| KHDL712-12 | 60          | 12,000        | 84 x 144               | 9,000              | 6,000               | 14                  | 7.5 | 7                       | 4,570            |
| KHDL712-15 | 60          | 15,000        | 84 x 144               | 11,200             | 7,500               | 14                  | 7.5 | 7                       | 4,670            |
| KHDL712-20 | 60          | 20,000        | 84 x 144               | 15,000             | 10,000              | 18                  | 10  | 9                       | 6,760            |
| KHDL88-10  | 60          | 10,000        | 96 x 96                | 7,500              | 5,000               | 14                  | 7.5 | 9                       | 3,450            |
| KHDL88-12  | 60          | 12,000        | 96 x 96                | 9,000              | 6,000               | 14                  | 7.5 | 9                       | 3,600            |
| KHDL88-15  | 60          | 15,000        | 96 x 96                | 11,200             | 7,500               | 14                  | 7.5 | 9                       | 3,700            |
| KHDL88-20  | 60          | 20,000        | 96 x 96                | 15,000             | 10,000              | 18                  | 10  | 12                      | 5,830            |
| KHDL89-10  | 60          | 10,000        | 96 x 108               | 7,500              | 5,000               | 14                  | 7.5 | 9                       | 3,610            |
| KHDL89-12  | 60          | 12,000        | 96 x 108               | 9,000              | 6,000               | 14                  | 7.5 | 9                       | 3,760            |
| KHDL89-15  | 60          | 15,000        | 96 x 108               | 11,200             | 7,500               | 14                  | 7.5 | 9                       | 3,860            |
| KHDL89-20  | 60          | 20,000        | 96 x 108               | 15,000             | 10,000              | 18                  | 10  | 12                      | 5,990            |
| KHDL810-10 | 60          | 10,000        | 96 x 120               | 7,500              | 5,000               | 14                  | 7.5 | 9                       | 3,720            |
| KHDL810-12 | 60          | 12,000        | 96 x 120               | 9,000              | 6,000               | 14                  | 7.5 | 7.5                     | 3,760            |
| KHDL810-15 | 60          | 15,000        | 96 x 120               | 11,200             | 7,500               | 14                  | 7.5 | 7.5                     | 3,860            |
| KHDL810-20 | 60          | 20,000        | 96 x 120               | 15,000             | 10,000              | 18                  | 10  | 10                      | 6,400            |
| KHDL812-10 | 60          | 10,000        | 96 x 144               | 7,500              | 5,000               | 14                  | 7.5 | 7                       | 4,580            |
| KHDL812-12 | 60          | 12,000        | 96 x 144               | 9,000              | 6,000               | 14                  | 7.5 | 7                       | 4,730            |
| KHDL812-15 | 60          | 15,000        | 96 x 144               | 11,200             | 7,500               | 14                  | 7.5 | 7                       | 4,830            |
| KHDL812-20 | 60          | 20,000        | 96 x 144               | 15,000             | 10,000              | 18                  | 10  | 9                       | 7,000            |

